

A2 SERIES

POSITIVE FEED DRILLS

**Recoules
Quackenbush®**
Precision Drilling - Every Time

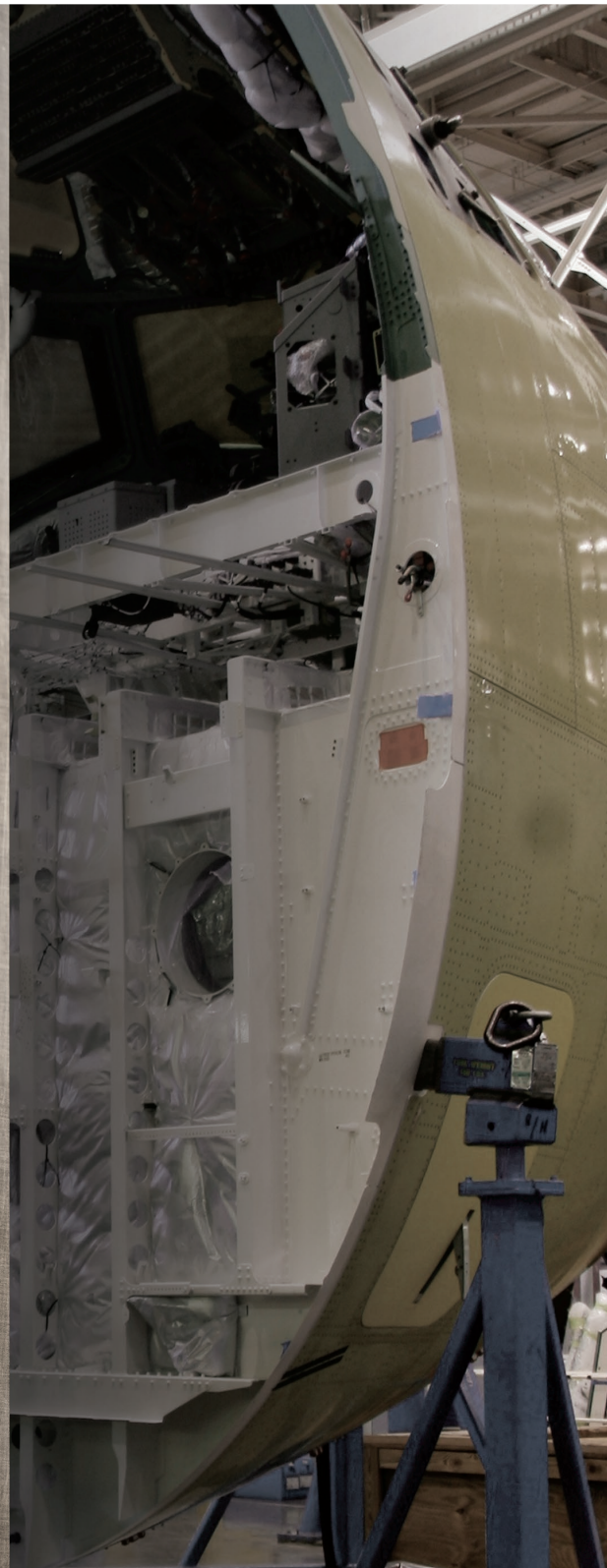

EASYCHANGE
FOR FEED RATE AND MITIS™

- Feed change in less than 15 minutes (Allows easy configuration and/or less time to repair)
- Mitis™ change in less than 15 minutes* (Allows easy configuration and/or less time to repair)



EXTRALIFE
NO IMPACT CONE CLUTCH FOR RETRACT MECHANISM

- Improved reliability
- No impact, less servicing
- Easy access for servicing
- Lower service cost

LIFTSWITCH
MECHANICAL INITIATION OF RETRACT

- Improved reliability
- Longer life
- Less defects
- Depth/dwell incorporated for accurate countersinking +/- 0.001" (0.03mm)

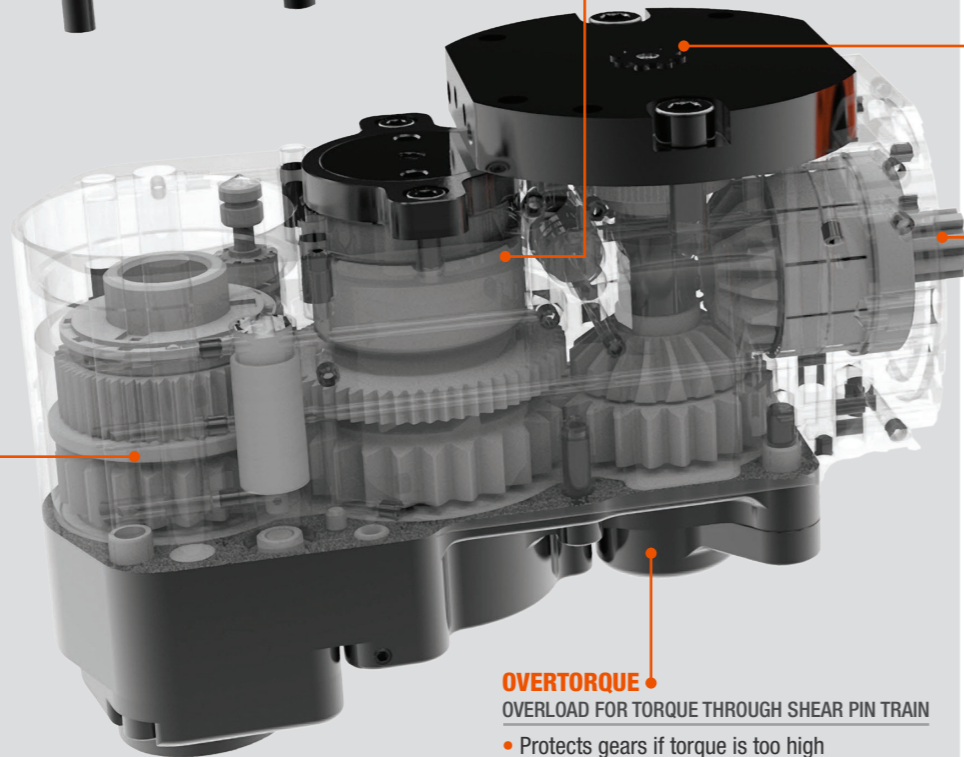

OVERTORQUE
OVERLOAD FOR TORQUE THROUGH SHEAR PIN TRAIN

- Protects gears if torque is too high
- Longer gear head life
- Keeps tool weight down
- Can prevent drilling with damaged cutter
- Less hole defects

LOGIPORT
AVAILABLE CONNECTION FOR ACCESSORIES/ERROR-PROOFING

- Allows easy implementation of:
 - Remote start
 - Start safety interlock
 - Air supply to accessories
 - Remote retract
 - Cycle complete
- Makes customization easier
- Coolant shut-off in retract
- Get the configuration you want in less time



FLEXMOTOR

- Available in Right Angle or Inline Configuration



FLEXPOWER
VANE- AND TURBINE-GOVERNED MOTOR OPTIONS

- Wide range of speed options through modular planetary gearboxes
- Governed Turbine and Vane modular motor choices easily interchanged

CONFIGURATION OPTION EXAMPLES



* Mitis Chip Fragmentation System

INCREASE PRODUCTIVITY

- Drill and 100% countersink capable with MITIS™ chip fragmentation
- Most flexible power train design configurable to minimize speed drop
- Turbine 2.2hp/1.6kW, Vane 1.4hp/1kW at spindle for maximum speed/torque
- Integrated MITIS™ for optimum chip evacuation

LOW OPERATING COST

- Up to 500 hours/100000 cycle PM interval**
- Uniquely configurable power train to maximize cutter life
- Selectable turbine/vane motors to minimize operating cost based on usage
- Grease ports, self contained bearings and captive O-rings reduce service costs

LOW MAINTENANCE

- Up to 500 hours/100000 cycle PM interval**
- Access service parts without total tear-down
- Extralife clutch accessible for change in less than 15 minutes
- Easy-change access to change both feed and MITIS™ in less than 15 minutes

QUALITY

- Configurable error-proofing
- Anti-jam spindle
- Add on counter for operator independent cutter change
- Minimized speed drop for consistent hole quality

** Mitis™ may require more frequent PM, refer to service manual

PRODUCT SPECIFICATIONS

Tool thrust 400lbs at 90psi/6.3bar dynamic air supply

A2 SERIES BASE TOOL OPTIONS

Base Tool				Standard Option		Rated Speeds -0/+20%		Feeds	
Code	Base Weight lbs	kg	Noise	Configuration	Code	Configuration	Turbine	ipr	mm/rev
TURBINE Turbine Max Spindle Power 2.2 hp / 1.6kW at 90 psi / 6.3 bar dynamic air supply									
A24T	5.2	2.4	<=85dBA	Right Angle	Turbine	M Internal Mitis F3 - 1.5 times per rev F5 - 2.5 times per rev Amplitudes (mm) 0.10 0.15 0.20 0.25 0.30 0.35	5400, 4400, 4000, 3400, 2700, 1800, 1200, 1000, 850, 700, 650, 550, 450	0.001 0.002 0.003 0.004 0.006 0.007 0.008 0.010	0.025 0.051 0.076 0.102 0.152 0.178 0.203 0.250
A26T	5.0	2.3	<=85dBA	In Line	Turbine				

VANE

Vane Max Spindle Power 1.4 hp / 1kW at 90 psi / 6.3 bar dynamic air supply

A24V	5.5	2.5	<=82dBA	Right Angle	Vane	M Internal Mitis F3 - 1.5 times per rev F5 - 2.5 times per rev Amplitudes (mm) 0.10 0.15 0.20 0.25 0.30 0.35	5200, 4500, 4200, 3900, 3700, 3300, 2900, 2600, 2300, 1700, 1500, 1150, 1000, 800, 700, 650, 600, 550, 480, 430, 400, 380, 320, 250	0.001 0.002 0.003 0.004 0.006 0.007 0.008 0.010	0.025 0.051 0.076 0.102 0.152 0.178 0.203 0.250
A26V	5.3	2.4	<=82dBA	In Line	Vane				

Product Specifications subject to change without notice

A2 SERIES CUSTOM TOOL OPTIONS & ACCESSORIES

Spindles	<ul style="list-style-type: none"> Specified based on stroke requirement and cutter thread interface 	
Nose Attachments	<ul style="list-style-type: none"> Specified based on application requirements: Concentric collet Twist lock: standard and vacuum Template foot Indexers Compatible with existing 1"-20 noses 	
Other Options	<ul style="list-style-type: none"> Spindle guards: specified to suit spindle and coolant method used, compatible with existing 15QRHD spindle guards Handles: based on application requirements Electronic counter: for cutter count, maintenance, and overall tool life Lubricators: on-board and floor pump models available 	
<p>* Visit our website to submit an application inquiry: www.quackenbushtools.com/tools/advanced-drilling-equipment</p>		

North America | South America

Apex Tool Group
670 Industrial Drive
Lexington, SC 29072
Phone: +1 (803) 951 7510
Fax: +1 (803) 996 2400
www.apexpowertools.com
Apex@apextoolgroup.com

Apex Tool Group
Manufacturing México
S. de R.L. de C.V.
Vialidad El Pueblito #103
Parque Industrial Querétaro
Querétaro, QRO 76220
Mexico
Tel: +52 (442) 211 3800
Fax: +52 (800) 685 5560

Apex Tool Group
Ind. Com. Ferram. Ltda.
Av. Liberdade, 4055
Zona Industrial Iporanga
Sorocaba, São Paulo
CEP# 18087-170
Brazil
Tel: +55 15 3238 3820
Fax: +55 15 3238 3938

Europe | Middle East | Africa

Apex Tool Group GmbH
Industriestraße 1
73463 Westhausen
Germany
Phone: +49 (0) 73 63 81 0
Fax: +49 (0) 73 63 81 222

Apex Tool Group S.A.S.
25 rue Maurice Chevalier
B.P. 28
77831 Ozoir-la-Ferrière
Cedex, France
Tel: +33 1 64 43 22 00
Fax: +33 1 64 43 17 17

Apex Tool Group
Hungária Kft.
Platánfa u.2
9027 Győr
Hungary
Tel: +36 96 66 1383
Fax: +36 96 66 1135

Asia Pacific

Apex Power Tool Trading
(Shanghai) Co., Ltd.
2nd Floor, Area C
177 Bi Bo Road
Pu Dong, New Area,
Shanghai
China 201203, P.R.C.
Phone: +86 21 60880320
Fax: +86 21 60880298

Apex Power Tools India
Private Limited
Gala No. 1, Plot No. 5
S. No. 234, 235 & 245
Indialand Global Industrial Park
Taluka-Mulsi, Phase I
Hinjawadi, Pune 411057
Maharashtra, India
Phone: +91 020 66761111

